

## Water Management System Using Wireless Embedded Web Server



**P. Dilip Yadav**

M.Tech 2<sup>nd</sup> Year,  
Embedded Systems,  
Malla Reddy Institute of  
Engineering and Technology.



**Dr. M. Narsing Yadav, M.S, Ph.D**

HOD,  
Dept of ECE,  
Malla Reddy Institute of  
Engineering and Technology.



**M. Naresh M. Tech**

Assistant Professor,  
Dept of ECE,  
Malla Reddy Institute of  
Engineering and Technology.

### Abstract:

The sensors are fixed at specified locations on the container. The water level sensor triggers one-by-one based on the water level. Microcontroller monitors the liquid level and the level displayed on LCD. If the maximum level is reached, the microcontroller switches off the motor. If the liquid reaches the lower level, the controller drives the driver circuit and switches on the motor. The sensed level values of the water are displayed on the 16x2-line LCD. This project is specially designed for household, Industries. Water level sensors / Reed switches are used as level sensors. The level of the water is monitored by the microcontroller and displayed on LCD. At the same time all the information will be available on web server using IoT module interfaced to the controller. Water consumption measurement is also being done here using flow sensor. This is fixed near each pipeline of individual's water supply. So that one can have details about their water bill also.

### Introduction:

In our daily life we use water for many purposes and in some cases wastage will be done to avoid that this project is very helpful. If a system is developed for automation of pump for filling the container or tank, no operator is required for supervising the system. Automatic water level controllers and generating the readings are the main concepts involved here.

### Existing Method:

This project is specially designed for household, Industries. Magnetic sensors / Reed switches are used as level sensors. The level of the water is monitored by the microcontroller and displayed on LCD. Here a buzzer alert will be given whenever the water reaches extreme low / high levels. A water pump is also connected to the controller to switch on/off the motor automatically when ever required.

### Block diagram:

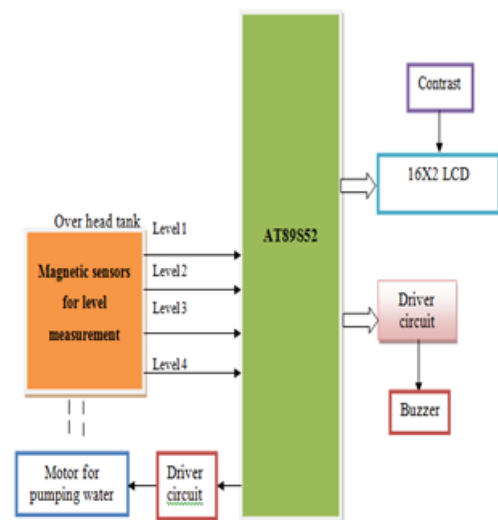

### Draw backs:

There is no calculation of water given to the individual, So bill cannot be generated accordingly. No information is being sent.

### Proposed Method:

The sensors are fixed at specified locations on the container. The water level sensor triggers one-by-one based on the water level. Microcontroller monitors the liquid level and the level displayed on LCD. If the maximum level is reached, the microcontroller switches off the motor. If the liquid reaches the lower level, the controller drives the driver circuit and switches on the motor. The sensed level values of the water are displayed on the 16x2-line LCD. This project is specially designed for household, Industries. Magnetic sensors / Reed switches are used as level sensors. The level of the water is monitored by the microcontroller and displayed on LCD. At the same time all the information will be available on web server using IoT module interfaced to the controller. Water consumption measurement is also being done here using flow sensor. This is fixed near each pipeline of individual's water supply. So that one can have details about their water bill also.

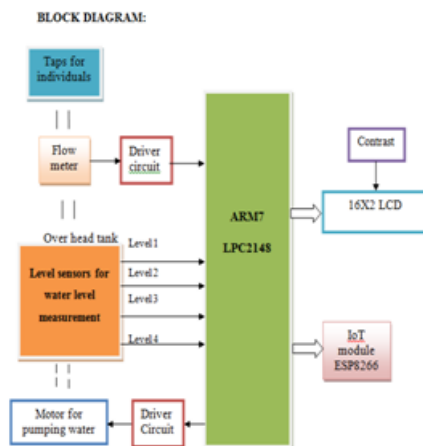

### Modules Used In This Project:

The LPC2148 are based on a 16/32 bit ARM7TDMI-S™ CPU with real-time emulation and embedded trace support, together with 128/512 kilobytes of embedded high speed flash memory. A 128-bit wide memory interface and unique accelerator architecture enable 32-bit code execution at maximum clock rate. For critical code size applications, the alternative 16-bit Thumb Mode reduces code by more than 30% with

minimal performance penalty. With their compact 64 pin package, low power consumption, various 32-bit timers, 4- channel 10-bit ADC, USB PORT, PWM channels and 46 GPIO lines with up to 9 external interrupt pins these microcontrollers are particularly suitable for industrial control, medical systems, access control and point-of-sale. With a wide range of serial communications interfaces, they are also very well suited for communication gateways, protocol converters and embedded soft modems as well as many other general-purpose applications.

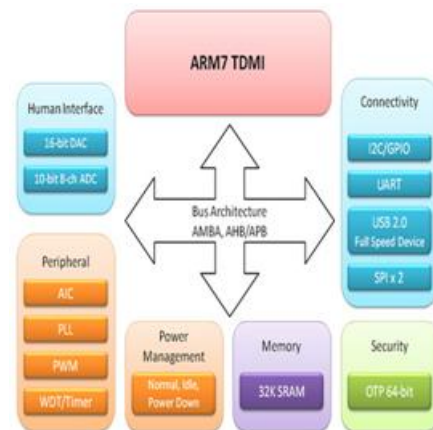

This project uses regulated 3.3V, 500mA power supply. Unregulated 12V DC is used for relay. 7805 three terminal voltage regulator is used for voltage regulation. Bridge type full wave rectifier is used to rectify the ac output of secondary of 230/12V step down transformer.

### ARM7TDMI Processor Core

- Current low-end ARM core for applications like digital mobile phones
- TDMI
  - T: Thumb, 16-bit compressed instruction set
  - D: on-chip Debug support, enabling the processor to halt in response to a debug request
  - M: enhanced Multiplier, yield a full 64-bit result, high performance
  - I: Embedded ICE hardware
- Von Neumann architecture

### Flow Sensor:

Water flow sensor consists of a plastic valve body, a water rotor, and a hall-effect sensor. When water flows through the rotor, rotor rolls. Its speed changes with different rate of flow. The hall-effect sensor outputs the corresponding pulse signal. This one is suitable to detect flow in water dispenser or coffee machine.



### Features:

- Compact, Easy to Install
- High Sealing Performance
- High Quality Hall Effect Sensor
- RoHS Compliant

### Specifications:

- Mini. Working Voltage: DC 4.5V
- Max. Working Current: 15mA (DC 5V)
- Working Voltage: DC 5V~24V
- Flow Rate Range: 1~30L/min
- Load Capacity:  $\leq 10$ mA (DC 5V)
- Operating Temperature:  $\leq 80$ °C
- Liquid Temperature:  $\leq 120$ °C
- Operating Humidity: 35% ~ 90%RH
- Water Pressure:  $\leq 1.75$ MPa
- Storage Temperature: -25 ~ + 80°C
- Storage Humidity: 25% ~ 95%RH

### Level sensors:

level sensors are used to detect the level of the water in the overhead tank.



Mini.Working voltage: DC 5V

Working current :4-20mAmps

### Submersible Pump:

A submersible pump (or sub pump, electric submersible pump (ESP)) is a device which has a hermetically sealed motor close-coupled to the pump body. The whole assembly is submerged in the fluid to be pumped. The main advantage of this type of pump is that it prevents pump cavitation, a problem associated with a high elevation difference between pump and the fluid surface. Submersible pumps push fluid to the surface as opposed to jet pumps having to pull fluids. Submersibles are more efficient than jet pumps.



### Applications:

Submersible pumps are found in many applications. Single stage pumps are used for drainage, sewage pumping, general industrial pumping and slurry pumping. They are also popular with pond filters. Multiple stage submersible pumps are typically lowered down a borehole and most typically used for residential, commercial, municipal and industrial water extraction (abstraction), water wells and in oil wells.

## LIQUID CRYSTAL DISPLAY:

A model described here is for its low price and great possibilities most frequently used in practice. It is based on the HD44780 microcontroller (Hitachi) and can display messages in two lines with 16 characters each. It displays all the alphabets, Greek letters, punctuation marks, mathematical symbols etc. In addition, it is possible to display symbols that user makes up on its own. Automatic shifting message on display (shift left and right), appearance of the pointer, backlight etc. are considered as useful characteristics.

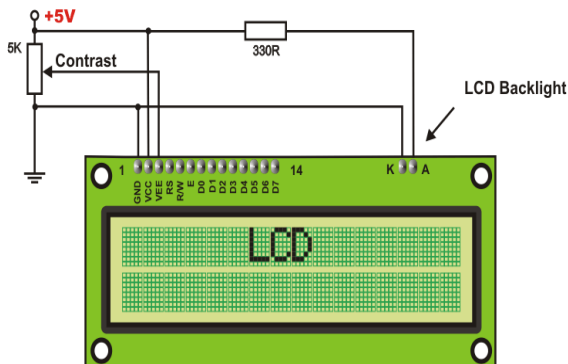

## IOT Module:

Espressif Systems' Smart Connectivity Platform (ESCP) is a set of high performance, high integration wireless SOCs, designed for space and power constrained mobile platform designers. It provides unsurpassed ability to embed WiFi capabilities within other systems, or to function as a standalone application, with the lowest cost, and minimal space requirement.

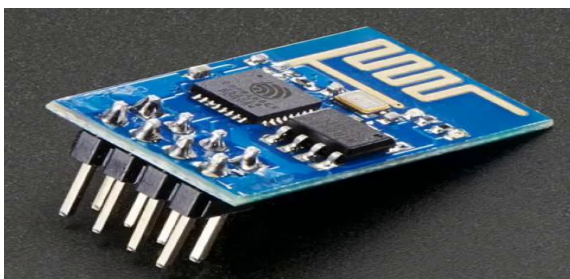

ESP8266EX offers a complete and self-contained WiFi networking solution; it can be used to host the application or to offload WiFi networking functions from another application processor.

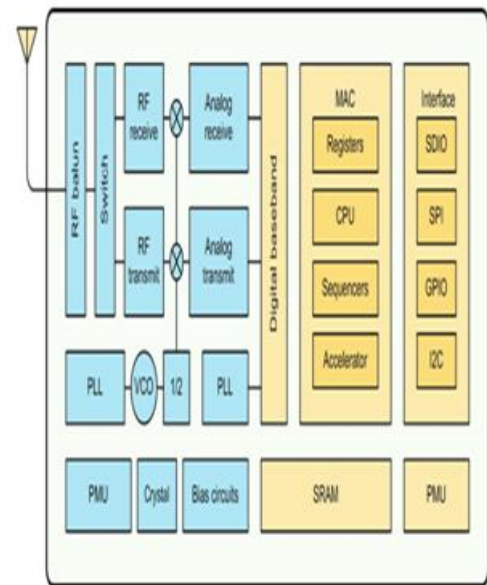

## Schematic:

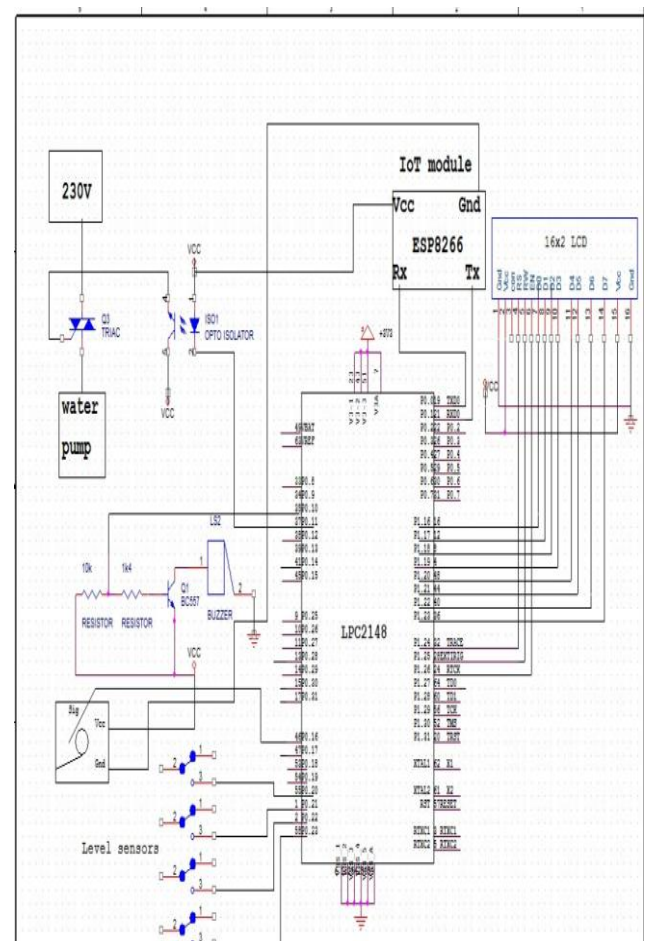

**Software Tools:**

Keil compiler is a software used where the machine language code is written and compiled. After compilation, the machine source code is converted into hex code which is to be dumped into the microcontroller for further processing. Keil compiler also supports C language code.

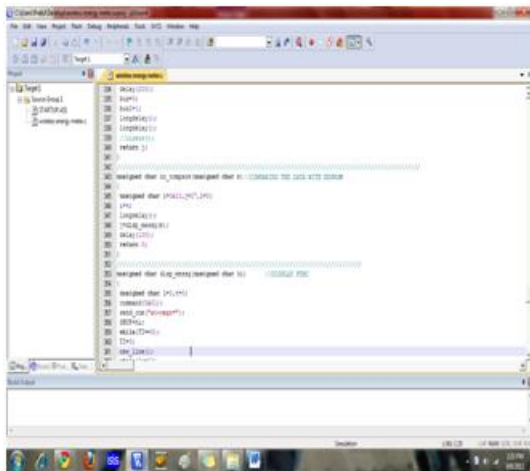

**Applications:**

- Gardens
- Parks
- Lawns

**Results:**



Fig a: flow meter connected to the tap



Fig b: Water flowing through tap across the flow meter

**Flash Magic:**

Flash Magic is a tool which is used to program hex code in EEPROM of micro-controller. It is a freeware tool. It only supports the micro-controller of Philips and NXP. It can burn a hex code into that controller which supports ISP (in system programming) feature. Flash magic supports several chips like ARM Cortex M0, M3, M4, ARM7 and 8051.



Step1: initializing the LCD

**Advantages:**

- Highly sensitive
- Fit and Forget system
- Low cost and reliable circuit

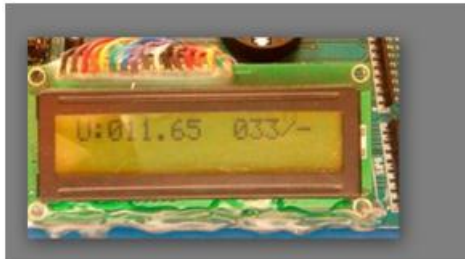

Step 2: generating the readings



Step 3

Step 3: indicates that water level in the tank is in level 1 and pump on indicates that motor pump is in “ON” state and starts filling the overhead tank.



Step 4

Step 4: indicates that the water level in the tank is in level 2 and pump on indicates that motor pump is in “ON” state continuously.



Step 5

Step5:indicates that the water level in the tank is in level 3 and motor pump is “ON” state continuously.



Step 6

Step 6: indicates that water level in the overhead tank is in level 4 i.e., the water level reached in the overhead tank to its maximum level and the motor pump gets off automatically

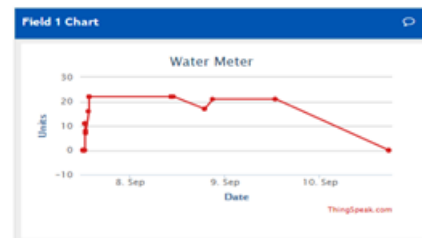

Fig c:

The graphical representation of the above chart can be seen in the web server with the help of channel id provided to the WIFI chip. The units indicating that water usage with respective to date .

### CONCLUSION:

Hence we have designed a simple, low-cost controller based water management system using ARM7 processor in which number of utilized units are displayed on LCD and also send to the web server based on flow sensor input. This project we can use in domestic and industrial purposes.

### Future Scope:

We are generating the readings for the water supplied from the overhead tank to the individual taps with the help of flow meter connected at the end of the taps. Generating the water bill with respective to the readings and for additional usage of water than required we are providing additional charge for that. With the help of level sensors we are filling the overhead tank automatically without any human effort.

With the help of IOT we can see how many litres of water used on particular date with time in the webserver with the help of IOT. In place of IOT, we can also use GSM so we can see the water usage on particular date with time and we can send the generated water bill to the number in the form of SMS which we are using.

## References:

[1] Dilip yadav, "Water management system using wireless embedded web server".

[2] "Water Management system using Dynamic IP based Embedded Web server in Real Time" 2015.

[3] Stanley Liu, "Overcoming IP address issues with GPRS Remote Monitoring and Alarm Systems", Moxa White paper-April 14, 2009.

[4] Wu Min-hua, "Research for the Embedded Web Server" college of Information Engineering, capital Norway University, Beijing. pp-776- 778.

[5] Ali ziya alkar, Mehmet atif karaca, "An internet based interactive embedded data acquisition system for real time applications," IEEE transaction on instrumentation and measurement, vol.58, No.3, pp.522-529, March 2009.

[6] Daogang Peng, Hao Zhang, Kai Zhang, "Research and Development of Remote I/O data acquisition System Based on Embedded ARM Platform", International Conference on Electronics Computer Technology-.pp-341-343, 2009.

[7] M.Schukat, M.P.Cullen, D.O.Beirne, "A Redundant Dynamic Host Configuration Protocol for Collaborating Embedded Systems", World Academy of Science, Engineering and Technology 3, pp-60-63, 2005.

[8] Huanming Yu, Zhifeng pang, Dongru Ruan, "The Design of the Embedded Wireless vehicles Monitoring Management System based on GPRS: Evidence from

China", International Symposium on Intelligent Information Technology Application Workshops (IITA). pp-677-680. IEEE-2008.

[9] Deepak C.Karia, Vispi Adajania, Manisha Agrawal and Swapnil Dandekar, "Embedded Web Server Application Based Automation and Monitoring System", Proceedings of 2011 International Conference on Signal Processing, Communication, Computing and Networking Technology, pp.634-637, 2011.

[10] ZhenXing Wang, Lin Xiang Shi, ZhongYuan Liu, Chaun Qun Jiang, "Embedded Web server and Database Based on Wap", International Conference on Computer and Automation Engineering", pp-200-204. IEEE-2009.

[11] V. Billy Rakesh Roy, Sanket Dessai, and S. G. Shiva Prasad Yadav, "Design and Development of ARM Processor Based Web Server" International Journal of Recent Trends in Engineering, Vol. 1, No. 4, pp-94-98. May 2009

[12] Behrouz A Forouzan, Data Communications and Networking, 4th Ed: Mcgraw-Hill, 2006.