

Traffic Information System Based on Smartphone



Narender Vaddepally
M.Tech (VLSI & ES),
Siddhartha Institute of
Engineering and Technology.



T. Naga Raju
Assistant Professor,
Siddhartha Institute of
Engineering and Technology.



Dr. Dasari Subba Rao
HoD,
Siddhartha Institute of
Engineering and Technology.

ABSTRACT:

Increasing smartphone penetration, combined with the wide coverage of cellular infrastructures, renders smart phone based traffic information systems (TISs) an attractive option. The main purpose of such systems is to alleviate traffic congestion that exists in every major city. Nevertheless, to reap the benefits of smartphone-based TISs, we need to ensure their security and privacy and their effectiveness (e.g., accuracy).

Existing System:

Traffic density is calculated using IR sensors. A siren alert is given when the density is high at that particular road. This is a signal for common man to avoid travelling through that road.

Proposed system

The project is built around MCU. Here we are using IR sensor. Here in our project we want to avoid to travel to the places/ on roads where there is huge traffic. So for that reason IR sensors are being placed at different locations of a road and the intensity of the traffic will be detected and that information will be sent to the controller. A Bluetooth module is interfaced to the controller where the data can be sent to the public. This can be implemented using smart phones. Here the driver or the traveller can receive the status of traffic using Bluetooth in their mobile. So that they can decide whether to travel through that route or not. This project uses regulated 5V, 500mA power supply. 7805 three terminal voltage regulator is used for voltage regulation. Bridge type full wave rectifier is used to rectify the ac out put of secondary of 230/12V step down transformer.

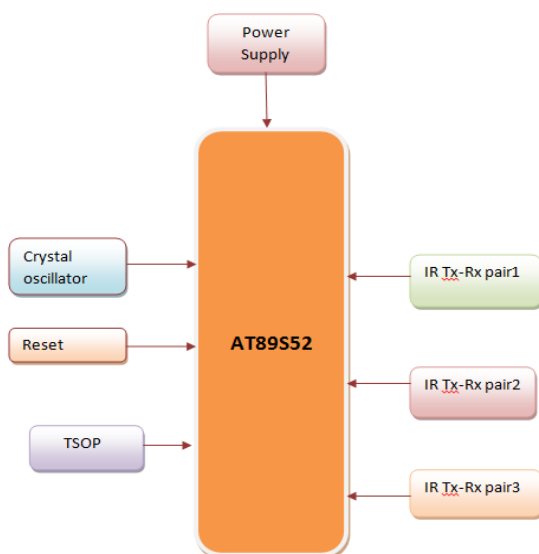

RASPBERRY-PI:



Drawback: No wireless communication

Block Diagram:

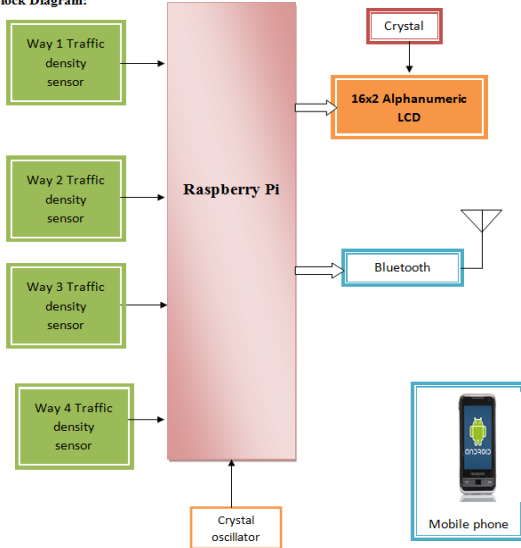

OS used in Raspberry pi is Linux

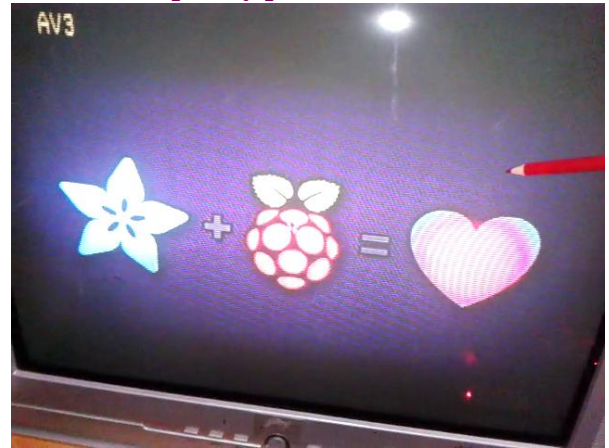

Coding will be done in python/C language

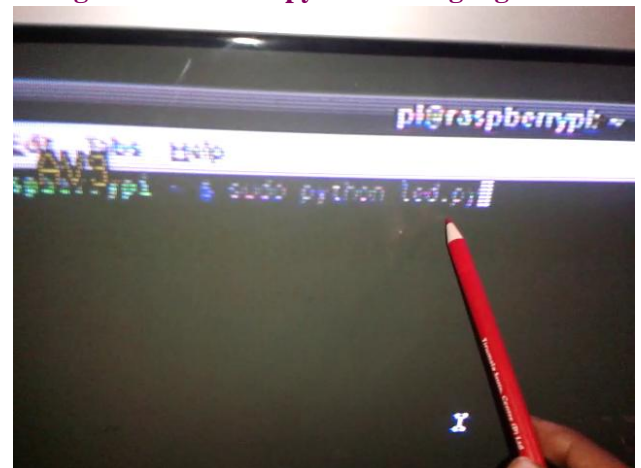

The **Raspberry Pi** has a Broadcom system on a chip (SoC).

Features:

- System Memory – 1GB LPDDR2
- Storage – micro SD card slot (push release type)
- Video & Audio Output – HDMI and AV via 3.5mm jack.
- Connectivity – 10/100M Ethernet
- USB – 4x USB 2.0 ports, 1x micro USB for power
- Expansion
- 2×20 pin header for GPIOs
- Camera header
- Display header
- Power – 5V via micro USB port.
- Dimensions – 85 x 56 mm

Basic Hardware of Raspberry-PI:

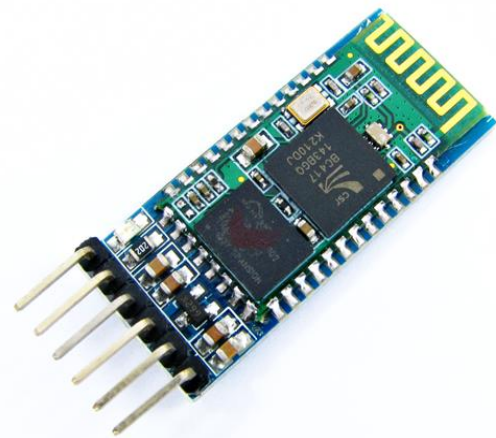
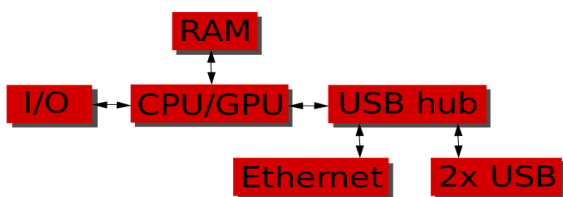

BLUETOOTH:

Bluetooth is a wireless technology standard for exchanging data over short distances (using short-wavelength radio transmissions in the ISM band from 2400–2480 MHz) from fixed and mobile devices, creating personal area networks (PANs) with high levels of security. Created by telecom vendor Ericsson in 1994, it was originally conceived as a wireless alternative to RS-232 data cables. It can connect several devices, overcoming problems of synchronization. Bluetooth dongle is simply defined as an accessory to the computer. By using a Bluetooth dongle a computer can be wirelessly linked to other devices. By using these dongles one can easily connect a computer with any other computer, printer, digital cameras or cellular devices. Actually Bluetooth dongle possesses a small microchip, which makes it capable of connecting and exchanging the data with all other devices which contain such microchips and with all other dongle devices. USB ports are used to connect a Bluetooth dongle with the computer. Just like other USB attachments these dongles also get powered from computers itself. Once we disconnect a Bluetooth dongle it gets deactivated on its own.

IR sensor:

IR reflectance sensors contain a matched infrared transmitter and infrared receiver pair. These devices work by measuring the amount of light that is reflected into the receiver. Because the receiver also responds to ambient light, the device works best when well shielded from ambient light, and when the distance between the sensor and the reflective surface is small (less than 5mm). IR reflectance sensors are often used to detect white and black surfaces. White surfaces generally reflect well, while black surfaces reflect poorly. One of such applications is the line follower of a robot.

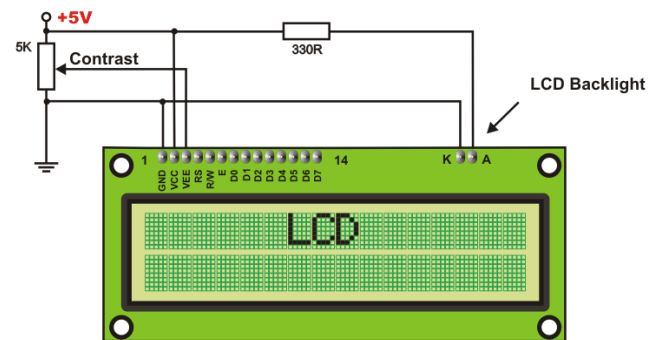
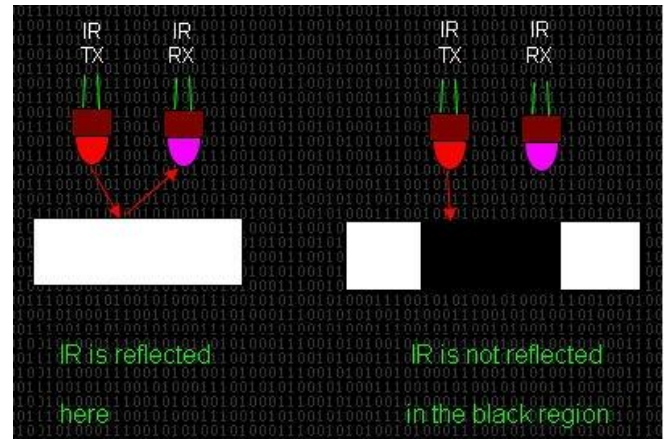

IR sensor schematic diagram

IR sensor circuit

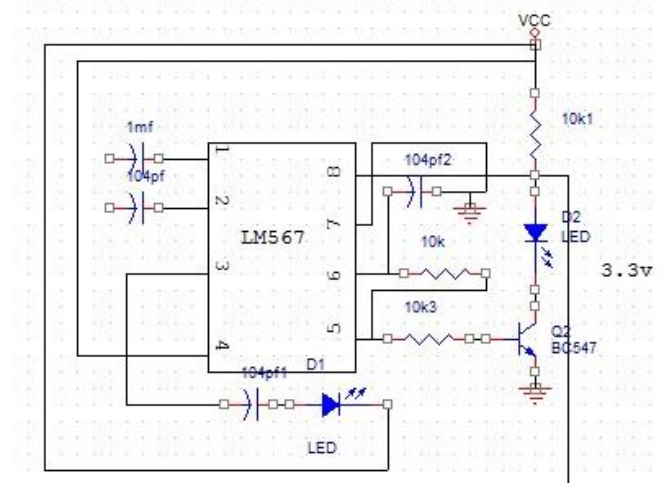

16x2 LCD:

LCD screen consists of two lines with 16 characters each. Each character consists of 5x7 dot matrix. Contrast on display depends on the power supply voltage and whether messages are displayed in one or two lines. For that reason, variable voltage 0-Vdd is applied on pin marked as Vee. Trimmer potentiometer is usually used for that purpose. Some versions of displays have built in backlight (blue or green diodes). When used during operating, a resistor for current limitation should be used (like with any LE diode).

Command	RS	RW	D7	D6	D5	D4	D3	D2	D1	D0	Execution Time
Clear display	0	0	0	0	0	0	0	0	0	1	1.64mS
Cursor home	0	0	0	0	0	0	0	0	1	x	1.64mS
Entry mode set	0	0	0	0	0	0	0	1	L/D	S	40uS
Display on/off control	0	0	0	0	0	0	1	D	U	B	40uS
Cursor/Display Shift	0	0	0	0	0	1	D/C	R/L	x	x	40uS
Function set	0	0	0	0	1	DL	N	F	x	x	40uS
Set CGRAM address	0	0	0	1	CGRAM address					40uS	
Set DDRAM address	0	0	1	DDRAM address					40uS		
Read "BUSY" flag (BF)	0	1	BF	DDRAM address					-		
Write to CGRAM or DDRAM	1	0	D7	D6	D5	D4	D3	D2	D1	D0	40uS
Read from CGRAM or DDRAM	1	1	D7	D6	D5	D4	D3	D2	D1	D0	40uS

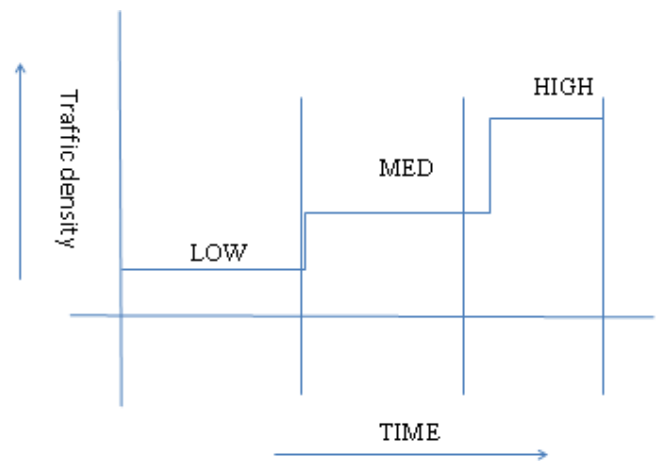
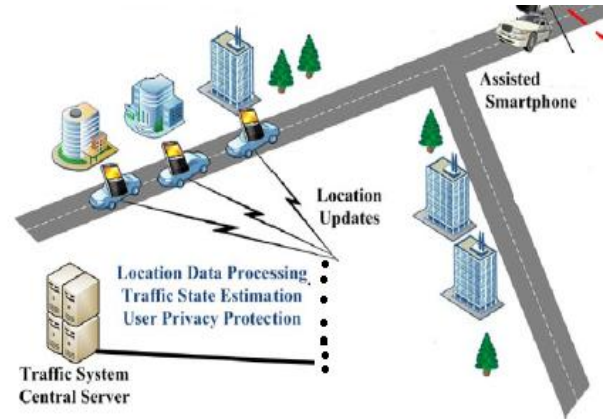

Graph Representation

Advantages:

- Accidents will be avoided
- Congestion will be controlled
- Fit and forget system
- Highly reliable
- Drivers will be alerted

Applications:

- Public Transportation
- Traffic junctions
- Transportation departments

Conclusion:

As road traffic is increasing day by day, monitoring it in an effective way has been the challenge to researchers. Since Smart phones are penetrating into common people’s lives very fast, utilizing the sensors available in them for traffic monitoring is a good idea. All this can be done in an energy efficient manner by using low energy consuming components

REFERENCES:

[1] S. Tao, V. Manolopoulos, S. Rodriguez, and A. Rusu, “Real-time urban traffic state estimation with A-GPS mobile phones as probes,” J. Transp. Technol., vol. 2, no. 1, pp. 22–31, Jan. 2011.



- [2] V. Manolopoulos, P. Papadimitratos, T. Sha, and A. Rusu, "Securing smartphone based ITS," in Proc. 11th Int. Conf. ITST, 2011, pp. 201–206.
- [3] V. Manolopoulos, S. Tao, A. Rusu, and P. Papadimitratos, "Smartphone based traffic information system for sustainable cities," ACM SIGMOBILE Mobile Comput. Commun. Rev., vol. 16, no. 4, pp. 30–31, Feb. 2013.
- [4] Y. Wang, M. Papageorgiou, and A. Messmer, "Real-time freeway traffic state estimation based on extended Kalman filter: A case study," Transp. Sci., vol. 41, no. 2, p. 167, May 2007.
- [5] J. Guo, J. Xia, and B. Smith, "Kalman filter approach to speed estimation using single loop detector measurements under congested conditions," J. Transp. Eng., vol. 135, no. 12, pp. 927–934, Dec. 2009.
- [6] M. A. Ferman, D. E. Blumenfeld, and X. Dai, "An analytical evaluation of a real-time traffic information system using probe vehicles," J. Intell. Transp. Syst., vol. 9, no. 1, pp. 23–34, 2005.
- [7] Y. Chen, L. Gao, Z. Li, and Y. Liu, "A new method for urban traffic state estimation based on vehicle tracking algorithm," in Proc. ITSC, 2007, pp. 1097–1101.
- [8] R. Clayford and T. Johnson, "Operational parameters affecting use of anonymous cell phone tracking for generating traffic information," in Proc. 82nd TRB Annu. Meet., 2003, pp. 1–20.
- [9] R. L. Cheu, C. Xie, and D. Lee, "Probe vehicle population and sample size for arterial speed estimation," Comput.-Aided Civil Infrastruct. Eng., vol. 17, no. 1, pp. 53–60, Jan. 2002.
- [10] M. A. Bacchus, B. Hellinga, and M. P. Izadpanah, "An opportunity assessment of wireless monitoring of network-wide road traffic conditions," Dept. Civil Eng., Univ. Waterloo, ON, Canada, 2007.
- [11] "ICT facts and figures," Geneva, Switzerland, Feb. 2013. [Online]. Available: <http://www.itu.int/en/ITU-D/Statistics/Documents/facts/ICTFactsFigures2013-e.pdf>
- [12] "Mobile future in focus," Reston, VA, USA, Feb. 2012. [Online]. Available: <https://www.comscore.com/Insights/Presentations-and-Whitepapers/2012/2012-Mobile-Future-in-Focus>
- [13] Y. Yim, "The state of cellular probes," Inst. Transp. Studies, Univ. Calif., Berkeley, CA, USA, Jul. 2003, Research Reports.
- [14] M. Fontaine, B. Smith, A. Hendricks, and W. Scherer, "Wireless location technology-based traffic monitoring: preliminary recommendations to transportation agencies based on synthesis of experience and simulation results," Transp. Res. Rec., J. Transp. Res. Board, vol. 1993, pp. 51–58, 2007.
- [15] J. C. Herrera et al., "Evaluation of traffic data obtained via GPS-enabled mobile phones: The Mobile Century field experiment," Transp. Res. C, Emerg. Technol., vol. 18, no. 4, pp. 568–583, Aug. 2010.
- [16] B. Hellinga, "Reducing bias in probe-based arterial link travel time estimates," Transp. Res. C, Emerg. Technol., vol. 10, no. 4, pp. 257–273, Aug. 2002.

Author's Details:

Narender Vaddepally, is an M.Tech (VLSI & EMBEDDED SYSTEMS) student in Department of Electronics & Communication Engineering, from Siddhartha Institute of Engineering and Technology, Ibrahimpatnam, Hyderabad, Telangana. His interest of fields in VLSI & Embedded systems and Networking.



International Journal of Research in Management Studies

A Peer Reviewed Open Access International Journal
www.ijrms

Email –Id: n.narenderns@gmail.com

Contact: +91 9493981541

T. Naga Raju, is an **Asst. Professor**, Received B.Tech degree in Electronics and Communication Engineering from the University of JNTU Hyderabad and M.Tech degree in VLSI System Design from the JNTU-Hyderabad. He is currently working as an Asst. Professor in ECE Department at Siddhartha Institute of Engineering & Technology, Hyderabad. Up to now he was attended several National and International Conferences. His current research interests include VLSI Design, Image Processing, Antennas & Microwave, Digital Signal Processing.

Dr. D Subba Rao, Ph.D, is a proficient Ph.D person in the research area of Image Processing from Vel-Tech University, Chennai along with initial degrees of Bachelor of Technology in Electronics and Communication Engineering (ECE) from Dr. S G I E T, Markapur and Master of Technology in Embedded Systems from SRM University, Chennai. He has 13 years of teaching experience and has published 12 Papers in International Journals, 2 Papers in National Journals and has been noted under 4 International Conferences. He has a fellowship of The Institution of Electronics and Telecommunication Engineers (IETE) along with a Life time membership of Indian Society for Technical Education (ISTE). He is currently bounded as an Associate Professor and is being chaired as Head of the Department for Electronics and Communication Engineering discipline at Siddhartha Institute of Engineering and Technology, Ibrahimpatnam, Hyderabad.

Email –Id: subbu.dasari@gmail.com

Contact: 09966779182

07893744445